

Model 3150-C

OPERATION MANUAL

Designed exclusively to operate with
GE Healthcare CT Scanners
GE Part Number: 5304770-2

Cardiac Trigger Monitor

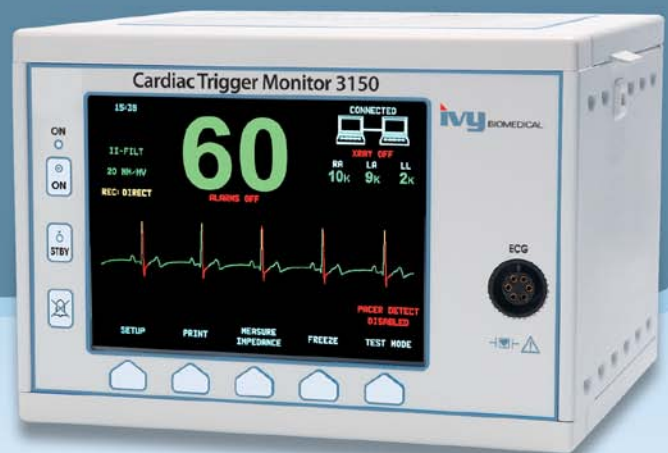

User Responsibility

This product will perform in conformity with the description thereof contained in this Operation Manual and accompanying labels and/or inserts, when assembled, operated, maintained and repaired in accordance with the instructions provided. This product must be checked periodically. A defective Product should not be used. Parts that are broken, missing, plainly worn, distorted or contaminated should be replaced immediately. Should such repair or replacement become necessary, IVY Biomedical Systems, Inc. recommends that a telephone call or written request for service advice be made to IVY Biomedical Systems, Inc. Service Department. This product or any of its parts should not be repaired other than in accordance with instructions provided by IVY Biomedical Systems, Inc. trained personnel. The product must not be altered without the prior written approval of IVY Biomedical Systems, Inc. Quality Assurance Department. The user of this Product shall have the sole responsibility for any malfunction, which results from improper use, faulty maintenance, improper repair, damage or alteration by anyone other than IVY Biomedical Systems, Inc.

CAUTION: US Federal law restricts this device to sale by or on the order of a licensed medical practitioner.

Ivy Biomedical Systems, Inc. has declared that this product conforms with the European Council Directive 93/42/EEC Medical Device Directive when its used in accordance with the instructions provided in the Operation and Maintenance Manual.



Ivy Biomedical Systems, Inc.

11 Business Park Drive

Branford, Connecticut 06405 USA

(203) 481-4183 • (800) 247-4614 • Fax (203) 481-8734

www.ivybiomedical.com Email: sales@ivybiomedical.com

OM3150-C 29 December 2011 2718-57-16 Rev.03

This page is intentionally left blank.

Declaration of Conformity

Manufacturer: Ivy Biomedical Systems, Inc.
11 Business Park Drive
Branford, CT 06405

Authorized Representative: Cavendish Scott Ltd.
Starlings Bridge, Nightingale Road
Hitchin, Herts, SG5 1FW, England

Type of Equipment: Physiological Monitors

Models: 3150 (C Option)

We, Ivy Biomedical Systems, Inc., hereby declare that the devices mentioned above comply with the Swedish National Board of Health and Welfare Regulation and guidelines on medical devices LVFS 2003:11 (M) 28 October 1994 – transposing European Medical Devices Directive 93/42/EEC.

Date of Validity: March 30, 2010

Classification: Iib According to rule No. 10

Conformity Assessment Procedure: Annex II

Notified Body: Intertek SEMKO AB Notified Body No. 0413

Name of Authorized Signatory: Dick Listro
Position held in Company: Director of Regulatory

Signature

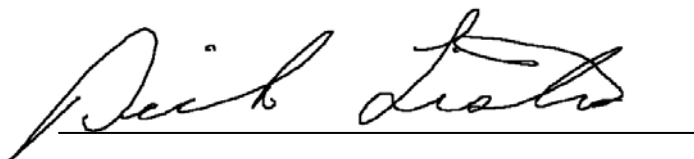

A handwritten signature in black ink, appearing to read 'Dick Listro', is written over a horizontal line.

This page is intentionally left blank.

Table of Contents

WARRANTY	iii
INTRODUCTION	1
SAFETY	2
Electrical.....	2
Explosion	2
Patient Connections.....	3
MRI.....	3
Pacemakers.....	3
Electrosurgery Protection.....	3
Defibrillation Protection	3
EMC.....	3
Electromagnetic Compatibility IEC 60601-1-2:2007	3
Description of Warning Labels.....	7
MONITOR DESCRIPTION.....	8
Intended Use.....	9
Classification	9
Control and Indicators.....	10
Basic Keys.....	10
Programmable Keys	11
Menu Structure	12
Display	13
Alarm Messages	14
Rear Panel	14
Fuse Ratings	15
MONITOR SETUP	16
Set up the instrument for operation	16
Change Mains Voltage	16
Set the Language.....	16
Set Time, Date, and Audio	16
Trace Speed.....	17
Default Settings.....	17
SYNCHRONIZED OUTPUT (TRIGGER)	18
The Synch Pulse	18
Trigger-Mark Display	18
Polarity Lock (P-Lock).....	18
ECG MONITORING	19
Safety Considerations.....	19
Patient Connections.....	20
ECG Electrodes.....	21
Impedance Measurement	21
ECG Waveform Amplitude (Size)	22
Lead Selection	23
Low Signal Message	24
ECG Notch Filter.....	24
Alarm Limits	25

Table of Contents

Pacemaker	25
SYSTEM INTERLOCK OPERATION	26
System Interlock Messages	26
PATIENT IDENTIFICATION NUMBER	27
Patient Identification and other controls using ETHERNET MODE	27
ECG DATA STORAGE AND TRANSFER	28
ECG and Impedance Data Transfer using the USB Port	28
USB Port.....	28
RECORDER OPERATION	29
Changing Paper	29
Recorder Modes.....	30
Recorder Speed.....	31
Example Printout.....	31
ALARM MESSAGES	32
Low Signal message	32
Pacer Detect message	32
Check Electrode message	32
MONITOR TESTING	33
ECG Simulator.....	33
TROUBLESHOOTING	34
MAINTENANCE AND CLEANING	35
Monitor.....	35
Patient Cables	35
Preventive Maintenance.....	35
ACCESSORIES	36
ECG	36
Disposal.....	36
SPECIFICATIONS	37

WARRANTY

All products manufactured by Ivy Biomedical Systems, Inc. under normal use, are warranted to be free from defects in material and workmanship and to operate within published specifications, for a period of 13 months from date of original shipment.

All accessories such as patient cables and lead wires, supplied by Ivy Biomedical Systems, Inc. under normal use, are warranted to be free from defects in material and workmanship and to operate within published specifications, for a period of 90 days from date of original shipment.

If an examination by Ivy Biomedical Systems, Inc. discloses such product(s) or component part(s) to have been defective, then Ivy's obligation is limited at Ivy's option, to repair or replacement.

When a product or products need to be returned to the manufacturer for repair or examination, contact customer service personnel at Ivy Biomedical Systems, to obtain a Return Material Authorization number (RMA #) and the correct packing instructions:

Customer Service:

Telephone: (203) 481-4183 or (800) 247-4614

Fax: (203) 481-8734

Email: techline@ivybiomedical.com

All products being returned for warranty repair shall be shipped prepaid to:

Ivy Biomedical Systems, Inc.
11 Business Park Drive
Branford, CT 06405 USA

Ivy will prepay the shipment of the repaired or replacement product to customer at Ivy's expense.

WARRANTY

This page is intentionally left blank.

INTRODUCTION

This manual is to provide information on the correct use of the Model 3150-C Cardiac Trigger monitor. It is up to the user to ensure that any applicable regulations regarding the installation and operation of the monitor are observed.

The Model 3150-C is a Medical Electrical Equipment intended to monitor patients under medical supervision. The Model 3150-C monitor must be operated by trained and qualified medical personnel only.

Using This Manual

We recommend that you read this manual before operating the equipment. This manual is written to include all options. If your monitor does not include all options, menu selections and display data for those options will not appear on your monitor.

Use the Monitor Description section for general descriptions of controls and displays. For details on the use of each option, refer to the section of the manual dealing with the appropriate option.

Boldface type is used in text to refer to the labeling on user controls. Special brackets [] surround menu selections used with the programmable keys.

Manufacturer's Responsibility

The manufacturer of this equipment is responsible for the effects on safety, reliability, and performance of the equipment only if:

- Assembly operations, extensions, re-adjustments, or repairs are carried out by persons authorized by the manufacturer
- The electrical installation complies with all applicable regulations
- The equipment is used in accordance with the instructions in this manual

Incorrect operation or failure of the user to maintain the monitor in accordance with proper maintenance procedures relieves the manufacturer or his agent from all responsibility for consequent non-compliance, damage, or injury.

Ivy Biomedical Systems, Inc.

11 Business Park Drive
Branford, CT 06405 USA
(203) 481-4183 or (800) 247-4614
Fax (203) 481-8734
Email: techline@ivybiomedical.com

This manual explains how to set up and use the Model 3150-C. Important safety information is located throughout the manual where appropriate. **READ THE ENTIRE SAFETY INFORMATION SECTION BEFORE YOU OPERATE THE MONITOR.**

SAFETY

SAFETY



Electrical

This product is intended to be operated from a mains power source of nominally 100 to 230V~, 47 to 63 Hz and Maximum AC Power consumption: 45VA.

WARNING: To prevent electrical hazards to all personnel, this monitor must be properly grounded. Connect the monitor only to a three-wire, grounded, hospital grade receptacle. The three-conductor plug must be inserted into a properly wired three-wire receptacle; if a three-wire receptacle is not available, a qualified electrician must install one in accordance with the governing electric code.

WARNING: Do not under any circumstances remove grounding conductor from the power plug.

WARNING: The power cable supplied with this equipment provides for this protection. Do not attempt to defeat this protection by modifying the cable or by using ungrounded adapters or extension cables. The power cord and plug must be intact and undamaged. To disconnect the equipment from the mains power; unplug the power cord.

WARNING: Do not connect to an electrical outlet controlled by a wall switch or dimmer.

WARNING: If there is any doubt about the integrity of the protective ground conductor arrangement, do not operate the monitor until the AC power source protective conductor is fully functional.

WARNING: Do not place the monitor in any position that may cause it to fall on the patient. Do not lift the monitor by the power supply cord or patient cable.

WARNING: Electric shock hazard! Do not remove covers or panels. Refer service to qualified service personnel.

WARNING: To avoid electrical shock, disconnect the monitor from its power source before changing fuses. Replace fuses only with same type and rating T.5A, 250V (Metric 5x20mm).

WARNING: Do not clean monitor while it is on and/or plugged into a power source.

WARNING: If unit is accidentally wet, discontinue use until dry and then test unit for proper operation before reuse on a patient.

WARNING: This unit uses a common isolation path for the ECG leads. Do not connect any non-isolated accessories to the ECG input when connected to a patient, as this may compromise the safety of the unit. When attached to other devices, insure that the total chassis leakage currents of all units do not exceed 300 μ A.

Explosion

DANGER: Explosion hazard! Do not use this equipment in the presence of flammable anesthetics or other flammable substance in combination with air, oxygen-enriched environment or nitrous oxide.

Patient Connections

Patient connections are electrically isolated. For all connections use isolated probes. Don't let patient connections contact other conductive parts, including ground. See instructions for patient connections in this manual.

Carefully route patient cables to reduce the possibility of patient entanglement or strangulation.

Leakage current is limited internally by this monitor to less than 10 μ A. However, always consider cumulative leakage current that can be caused by other equipment used on the patient at the same time as this monitor.

To ensure that the leakage current protection remains within the specifications, use only the patient cables specified in this manual. This monitor is supplied with protected lead wires. *Do not use* cables and leads with unprotected lead wires having exposed conductors at the cable end. Unprotected lead wires and cables may pose an unreasonable risk of adverse health consequences or death.

Line isolation monitor transients may resemble actual cardiac waveforms and thus inhibit heart rate alarms. To minimize this problem, ensure proper electrode placement and cable arrangement.

If an alarm condition occurs while the alarms are set to off, neither visual nor audio alarms will be present.

MRI

The Model 3150-C should not be used within the magnetic field during Magnetic Resonance Imaging.

Pacemakers

Rate meters might continue to count the pacemaker rate during occurrences of cardiac arrest or some arrhythmias. Do not rely on rate meter alarms. *Keep pacemaker patients under close surveillance.*

Electrosurgery Protection

This equipment is protected against electrosurgery potentials. To avoid the potential of electrosurgery burns at monitoring sites, ensure proper connection of the electrosurgery return circuit as described by the manufacturer's instructions. If improperly connected, some electrosurgery units might allow energy to return through the ECG electrodes.

Defibrillation Protection

This equipment is protected up to 360 J defibrillator discharge. The monitor is internally protected to limit current through the electrodes to prevent injury to the patient and damage to the equipment as long as the defibrillator is used in conformance with the manufacturer's instructions.

EMC

This equipment has been certified to be protected to emissions and immunity according to IEC-60601-1-2.

Electromagnetic Compatibility IEC 60601-1-2:2007

CAUTION: Medical Equipment needs special precautions regarding EMC and needs to be installed and put into service according to the EMC information provided in the Operation Manual.

SAFETY

CAUTION: Portable and mobile RF communications equipment can affect medical electrical equipment.

WARNING: The Model 3150-C should not be used adjacent to or stacked with other equipment, however if adjacent or stacked use is necessary, the Model 3150-C should be observed to verify normal operation in the configuration in which it will be used.

Accessories

WARNING: The use of accessories other than those specified below may result in increased emissions or decreased immunity of the equipment.

Ivy P/N	GE P/N	Description
590317	E8007RE	Low noise, three lead ECG patient cable
590318	E8007RH	Set of three radiotranslucent lead wires
590342	E8007RG	Radiotranslucent ECG electrodes

Signal Amplitude

WARNING: The minimum patient physiological “R-wave” signal amplitude is 0.5 mV (AAMI EC-13 3.2.6.1). The use of the Model 3150-C, below the above amplitude value, may cause inaccurate results:

Guidance and manufacturer’s declaration – Electromagnetic emissions		
The Model 3150-C monitor is intended for use in the electromagnetic environment specified below. The customer or the user of the Model 3150-C should insure that they are used in such an environment.		
Emissions test	Compliance	Electromagnetic environment - guidance
RF emissions CISPR 11	Group 1	The Model 3150-C uses RF energy only for its internal function. Therefore, their RF emissions are very low and are not likely to cause any interference in nearby electronic equipment.
RF emissions CISPR 11	Class A	The Model 3150-C is suitable for use in all establishments other than domestic and those directly connected to the public low-voltage power supply network that supplies buildings used for domestic purposes.
Harmonic emissions IEC 61000-3-2	Class A	
Voltage fluctuations/ flicker emissions IEC 61000-3-3	Complies	

Guidance and manufacturer's declaration – Electromagnetic immunity			
The Model 3150-C monitor is intended for use in the electromagnetic environment specified below. The customer or the user of the Model 3150-C should insure that they are used in such an environment.			
Immunity test	IEC 60601 test level	Compliance level	Electromagnetic environment – guidance
Electrostatic discharge (ESD) IEC 61000-4-2	±6 kV contact ±8kV air	±6 kV contact ±8kV air	Floors should be wood, concrete, or ceramic tile. If floors are covered with synthetic material, the relative humidity should be at least 30%.
Electrical fast Transient/burst IEC 61000-4-4	±2 kV for power supply lines ±1 kV for input/output lines	±1.6 kV for power supply lines ±0.6 kV for input/output lines	Mains power quality should be that of a typical commercial or hospital environment.
Surge IEC 61000-4-5	±1 kV differential mode ±2 kV common mode	±1 kV differential mode ±2 kV common mode	Mains power quality should be that of a typical commercial or hospital environment.
Voltage dips, short interruptions, and voltage variations on power supply input lines IEC61000-4-11	<5 % U_T (>95 % dip in U_T) for 0.5 cycle 40 % U_T (60 % dip in U_T) for 5 cycles 70 % U_T (30 % dip in U_T) for 25 cycles <5 % U_T (>95 % dip in U_T) for 5 sec cycle	<5 % U_T (>95 % dip in U_T) for 0.5 cycle 40 % U_T (60 % dip in U_T) for 5 cycles 70 % U_T (30 % dip in U_T) for 25 cycles <5 % U_T (>95 % dip in U_T) for 5 sec cycle	Mains power quality should be that of a typical commercial or hospital environment. If the user of the Model 3150-C requires continued operation during power mains interruptions, it is recommended that the Model 3150-C be powered from an uninterruptible power supply.
Power frequency (50/60 Hz) magnetic field IEC 61000-4-8	3 A/m	Not applicable	Not applicable

SAFETY

Guidance and manufacturer's declaration – Electromagnetic immunity			
The Model 3150-C monitor is intended for use in the electromagnetic environment specified below. The customer or the user of the Model 3150-C should insure that they are used in such an environment.			
Immunity test	IEC 60601 test level	Compliance level	Electromagnetic environment – guidance
<p>Conducted RF IEC 61000-4-6</p> <p>Radiated RF IEC 61000-4-3</p>	<p>3 Vrms 150 kHz to 80 MHz</p> <p>3 V/m 80 MHz to 2.5 GHz</p>	<p>3 Vrms</p> <p>3 V/m</p>	<p>Portable and mobile RF communications equipment should be used no closer to any part of the Model 3150-C, including cables, than the recommended separation distance calculated from the equation applicable to the frequency of the transmitter.</p> <p>Recommended separation distance</p> <p>$d = 1.2 \sqrt{p}$</p> <p>$d = 1.2 \sqrt{p}$ 80 MHz to 800 MHz</p> <p>$d = 2.3 \sqrt{p}$ 800 MHz to 2.5 GHz</p> <p>Where p is the maximum output power rating of the transmitter in watts (W) according to the transmitter manufacturer and d is the recommended separation distance in meters (m).</p> <p>Field strengths from fixed RF transmitters, as determined by an electromagnetic site survey ^a, should be less than the compliance level in each frequency range ^b</p> <p>Interference may occur in the vicinity of the equipment marked with the following symbol:</p> 
NOTE 1 – At 80 MHz and 800 MHz, the higher frequency range applies.			
NOTE 2 – These guidelines may not apply in all situations. Electromagnetic propagation is affected by absorption and reflection from structures, objects, and people.			
<p>^a Field strengths from fixed transmitters, such as base stations for radio (cellular/cordless) telephones and land mobile radios, amateur radios, AM and FM radio broadcast, and TV broadcast cannot be predicted theoretically with accuracy. To assess the electromagnetic environment due to fixed RF transmitters, an electromagnetic site survey should be considered. If the measured field strength in the location in which the Model 3150-C is used exceeds the applicable RF compliance level above, the Model 3150-C should be observed to verify normal operation. If abnormal performance is observed, additional measures may be necessary, such as re-orienting or relocating the Model 3150-C.</p> <p>^b Over the frequency range 150 KHz to 80 MHz, field strengths should be less than 3 V/m.</p>			

Description of Symbols Used

	Attention, consult ACCOMPANYING DOCUMENTS before attempting to change power supply selection or carry out interconnections. Equipment connected should comply with IEC-60601-1 or IEC-950 with configuration to IEC-60601-1-1.		
	Type CF applied part, Defibrillator proof.		
	Equipotential ground connector adjacent to this symbol.		
	Fuse type/rating.		Output signal.
	ON		Input signal.
	Stand By (STBY)		Alternate Current (AC)
	Protective earth (ground)		Input/Output signal
	WEEE Compliance		
	Manufacturer		
	Caution - Electric shock hazard. Do not remove covers or panels. Refer service to qualified service personnel.		

MONITOR DESCRIPTION

MONITOR DESCRIPTION

The Model 3150-C Cardiac Trigger Monitor is an easy to use color monitor that display a patient's ECG waveform and heart rate. The ECG lead displayed can be selected from Leads I, II or III. In addition high and low heart rate alarm limits can be adjusted to bracket the patient's heart rate so that a violation of these limits produces an audible and visual indication of the violation. The color display has a single trace, large Heart Rate numbers and alphanumeric characters for other data, alarm messages, menus and user information.

The Model 3150-C monitor is intended primarily for use on patients in applications requiring precision R-wave synchronization such as timed imaging studies.

The Model 3150-C provides two Ethernet channels from a single RJ45 connector. The first channel provides two way communications between the monitor and the CT console for the transfer of ECG data, trigger timing data and the receipt of patient identification information. The second channel provides ECG data to the CT Gantry display. These functions will only operate when the Model 3150-C is electrically connected to a CT console and CT gantry capable of displaying ECG data.

The Model 3150-C has a USB drive that allows the operator to store and retrieve ECG data on a USB memory stick device. The Model 3150-C also has special hardware and software that allows for the measurement of ECG electrode impedance, prior to, during and after the CT scan.

An integral recorder is standard on the Model 3150-C, set up of recorder functions are made through the monitor menus.

Summary of main options

Model	USB Port	Chart Recorder	Impedance Measurement
3150-C	Standard	Standard	Standard

The Model 3150-C is suitable for use in presence of Electro-surgery.

The Model 3150-C is not intended for use with any other physiological monitoring unit.

The Model 3150-C is restricted to use on one patient at a time.

The Model 3150-C is not intended for home-care patient monitoring.

Intended Use

The Ivy Biomedical Model 3150 Patient Monitor is a simple to use instrument for monitoring the ECG and Heart Rate. It is designed for use in the ICU, CCU and operating room conditions. It can sound an alarm when the HR falls outside of preset limits. It provides an output pulse, synchronized to the R-wave for use in applications requiring precision R-wave synchronization.

The Model 3150 is limited to use by trained and qualified medical professionals. This product is not intended for home care monitoring.

Classification (in accordance with IEC-60601-1)

Protection against electric shock:	Class 1.
Degree of protection against electric shock:	Type CF applied part. Defibrillator proof: ECG
Degree of protection against harmful ingress of water Ordinary equipment:	IPX0 per IEC-60529
Methods of Maintenance and Cleaning:	See page 35
Degree of safety of application in the presence of a flammable anesthetic mixture with air or with oxygen or nitrous oxide:	Equipment not suitable for use in the presence of a flammable anesthetic mixture
Mode of operation:	Continuous

MONITOR DESCRIPTION

Controls and Indicators

Basic Keys



When the monitor is plugged into an AC power source the **ON** switch, when pressed, provides power to the monitor's electronic circuits.



The **STBY** switch, when pressed, disconnects power from the monitor's electronic circuits.
NOTE: To disconnect the monitor from the main power unplug the AC power cord.



Disables the audible and visual alarms for a two-minute period to allow the operator perform procedures that would otherwise set off the alarms. This avoids the problem of turning off the alarms and forgetting to turn them back on. Press this key again to return the alarms to normal before the two minutes have expired. Pressing **ALARM PAUSE** key for 3 seconds will turn alarms off. Press **ALARMS PAUSE** key again to reactivate the alarms. Pressing **ALARM PAUSE** key will pause the alarms for 120 seconds (2 minutes).

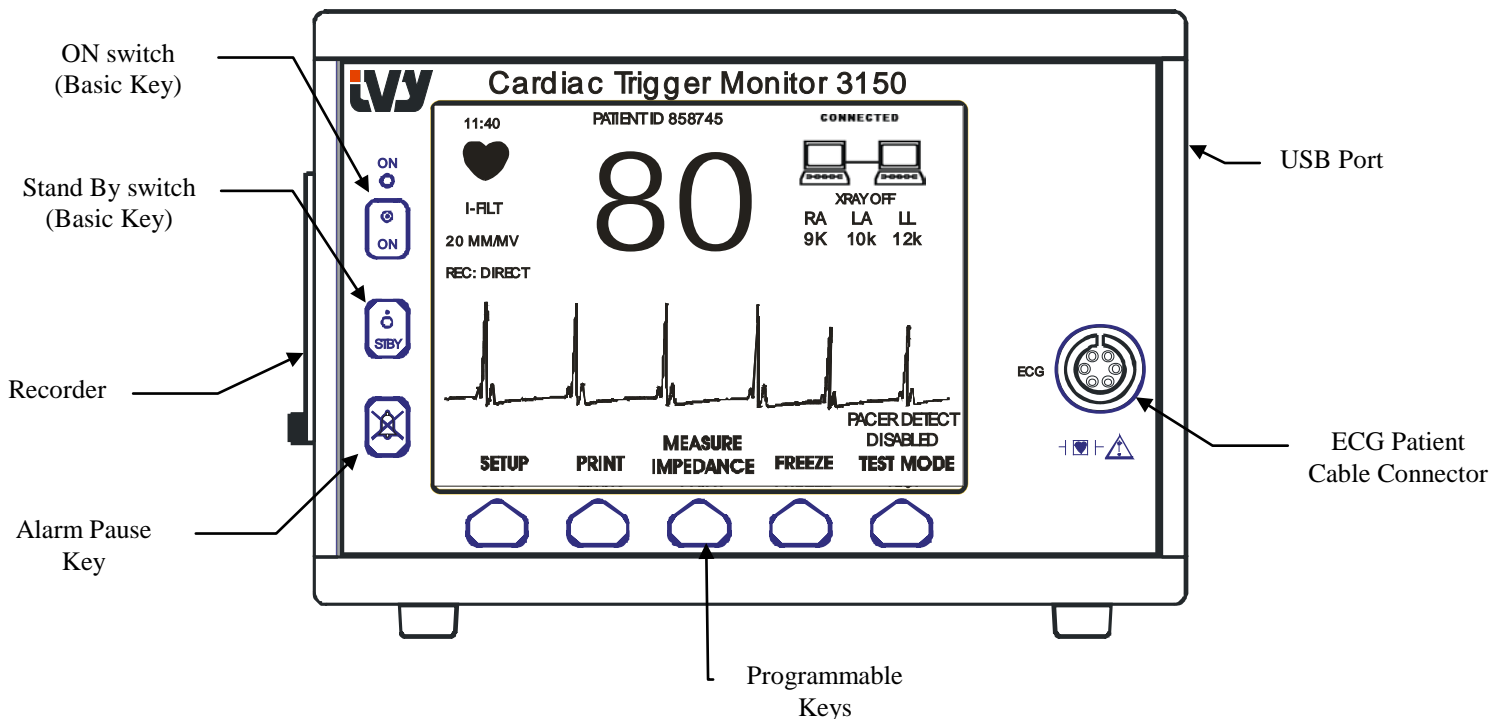

Programmable Keys

Displayed above each programmable key is either a menu item or a function. Pressing a programmable key will display other menu levels or activate an appropriate function. Menu functions are described in the Menu Structure section of this manual.

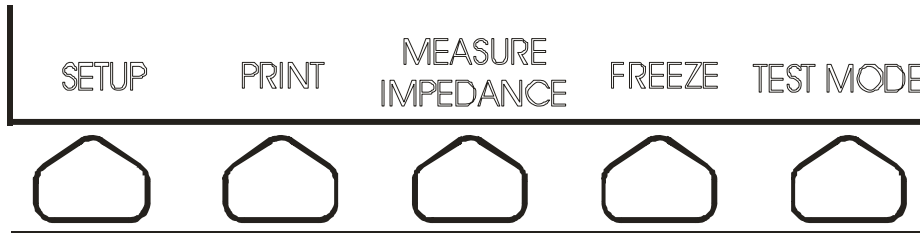

MONITOR DESCRIPTION

Menu Structure – Model 3150-C

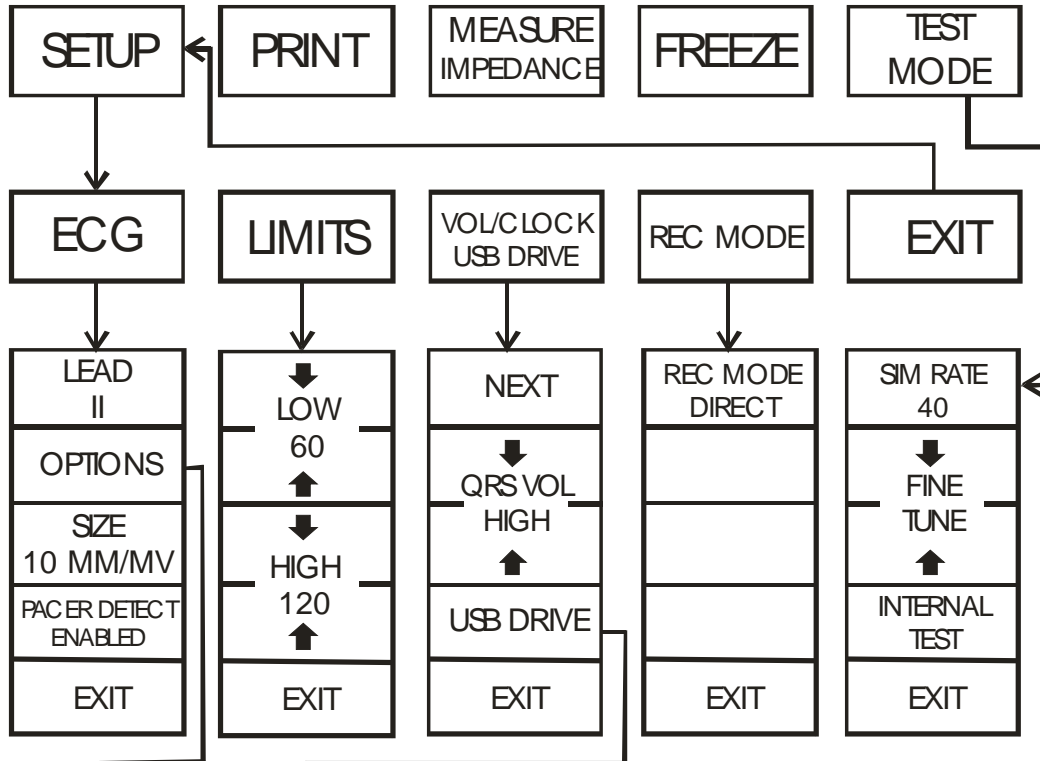

KEY SELECTIONS

ECG Menu

Lead: I - II - III
 SIZE: 5, 10, 20, and 40mm/mv
 PACER DETECT: ENABLED and DISABLED
OPTIONS MENU
 NOTCH FILTER: ON and OFF
 IMPEDANCE: ENABLED and DISABLED
 PLOCK: ENABLED and DISABLED

Limits Menu

Low: 10 to 245 bpm
 High: 15 to 250 bpm

Test Mode Menu

Sim Rate: OFF, 40, 60, 90, 120, and 150
 Fine Tune: 40 to 150 bpm

Speed Key:

25 and 50mm/s

Vol/Clock Menu

NEXT KEY

QRS Vol: OFF, High, and Low
 Alarm Vol: High and Low
 Month
 Day
 Year
 Hour
 Minute

Rec Mode Key:

Direct, Delay, Timed, HR-VAR, and X-RAY.

Display

HEART RATE: Displayed in beats per minute (bpm) on the upper part of the screen.

SETUP: Selections made in the menu setup modes (alarm limits, lead selection, and filter on/off) are displayed in small characters at the upper left corner.

ECG: Trace is displayed across the screen moving from left to right.

System Interlock: Large symbols in the upper right hand corner of the display provide the operator with a visual indication of the status of the connection between the Model 3150-C and the CT Scanner.

XRAY On/Off: Indicates that the CT-Scanner X-Ray is “ON” or the CT Scanner X-Ray is “OFF”. The XRAY On/Off indicator is located in the upper right hand corner of the display.

Impedance Measurement: Displays the measured value of the impedance between the patient’s skin and each individual ECG electrode (RA, LA, and LL). Impedance measurements are located in the upper right hand corner of the display.

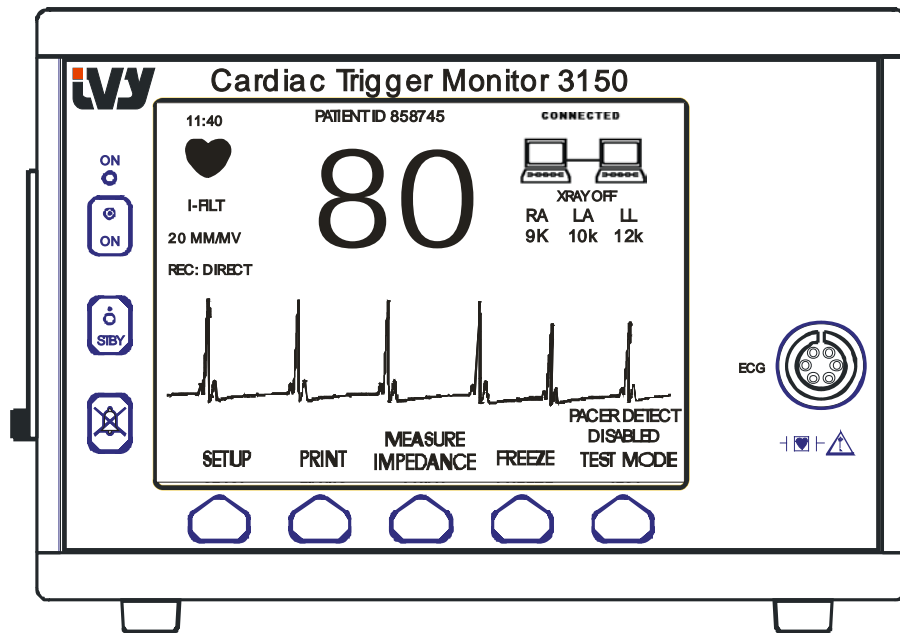

MONITOR DESCRIPTION

Alarm Messages

The following alarm indications are displayed in reverse video. Alarm indications appear on the center of the screen and flash once per second. ALARMS PAUSE message (PAUSE) is also displayed on the center of the screen and is displayed in regular video.

<i>ALARMS OFF:</i>	The audible and visual alarms have been turned off.
<i>LEAD OFF:</i>	A lead has become disconnected. This alarm cannot be reset with the ALARM PAUSE key.
<i>HR HIGH:</i>	The high heart rate limit has been exceeded for four seconds.
<i>HR LOW:</i>	The low heart rate limit has been exceeded for four seconds.
<i>ASYSTOLE:</i>	The interval between heartbeats has exceeded six seconds.
<i>PAUSE:</i>	The alarms are paused for 120 seconds.

WARNING: The monitor always powers on with the ALARMS paused for 30 seconds and then they are set to ON.

Rear Panel:

POWER INPUT: A receptacle for a standard ac power cord.

When the monitor is connected to another piece of equipment, always make sure that each piece of connected equipment has its own separate ground connection.
--

Do not attempt to connect cables to these connectors without contacting your Biomedical Engineering Department. This is to ensure the connection complies with leakage current requirements of one of the following applicable standards: UL60601-1, CAN/CSA C22.2 No 601.1-M90, IEC 60601-2-25, and CE-MDD 93/42/EEC. The maximum non-destructive voltage that may be applied to these connectors is 5V.

SYNCHRONIZED OUTPUT: A BNC type connector for the output of the synch pulse indicating the timing of the peak of the R-wave. Limit to 100Hz bandwidth.

PEQ GROUND: Potential Equalization - A ground connection that can be used to ensure that no potential differences can develop between this equipment and other electrical equipment.

FUSE: Replace only with the same type and rating of fuse as indicated on the fuse rating label T.5A 250V (Metric 5x20mm).

ECG X1000 and SYNCHRONIZED OUTPUT: This is a ¼ stereo phone jack with an ECG analog waveform output on the tip, synch output on the ring, and common on the sleeve. Limit to 100Hz bandwidth.

AUXILIARY: A digital interface for device communication. This auxiliary output provides 5V and -8V with a maximum current of 20mA.

ETHERNET: This is a two-channel Ethernet output that provides an Ethernet protocol (10Base-T, IEEE 802.3) from a single RJ45 connector. The first channel connects the Model 3150-C and the CT scanner console to share data and control options. A second Ethernet channel from the same connector provides ECG data to the CT gantry display.

SERIAL NUMBER LABEL: The serial number label indicates the model number and a unique serial number for the monitor. The date of manufacture is encoded in the first 4 digits of the serial number using the YYMM format.

LINE VOLTAGE SELECTOR: Switch to select the input voltage range of the device (100 to 230V~, 47 to 63 Hz.).

The use of ACCESSORY equipment not complying with the equivalent safety requirements of this equipment may lead to a reduce level of safety of the resulting system. Consideration relating to the choice shall include:

- Use of the accessory in the PATIENT VICINITY
- Evidence that the safety certification of the ACCESSORY has been performed in accordance to the appropriate IEC 60601-1 and / or IEC 60601-1-1 harmonized national standard.

Model 3150-C

Rear Panel:

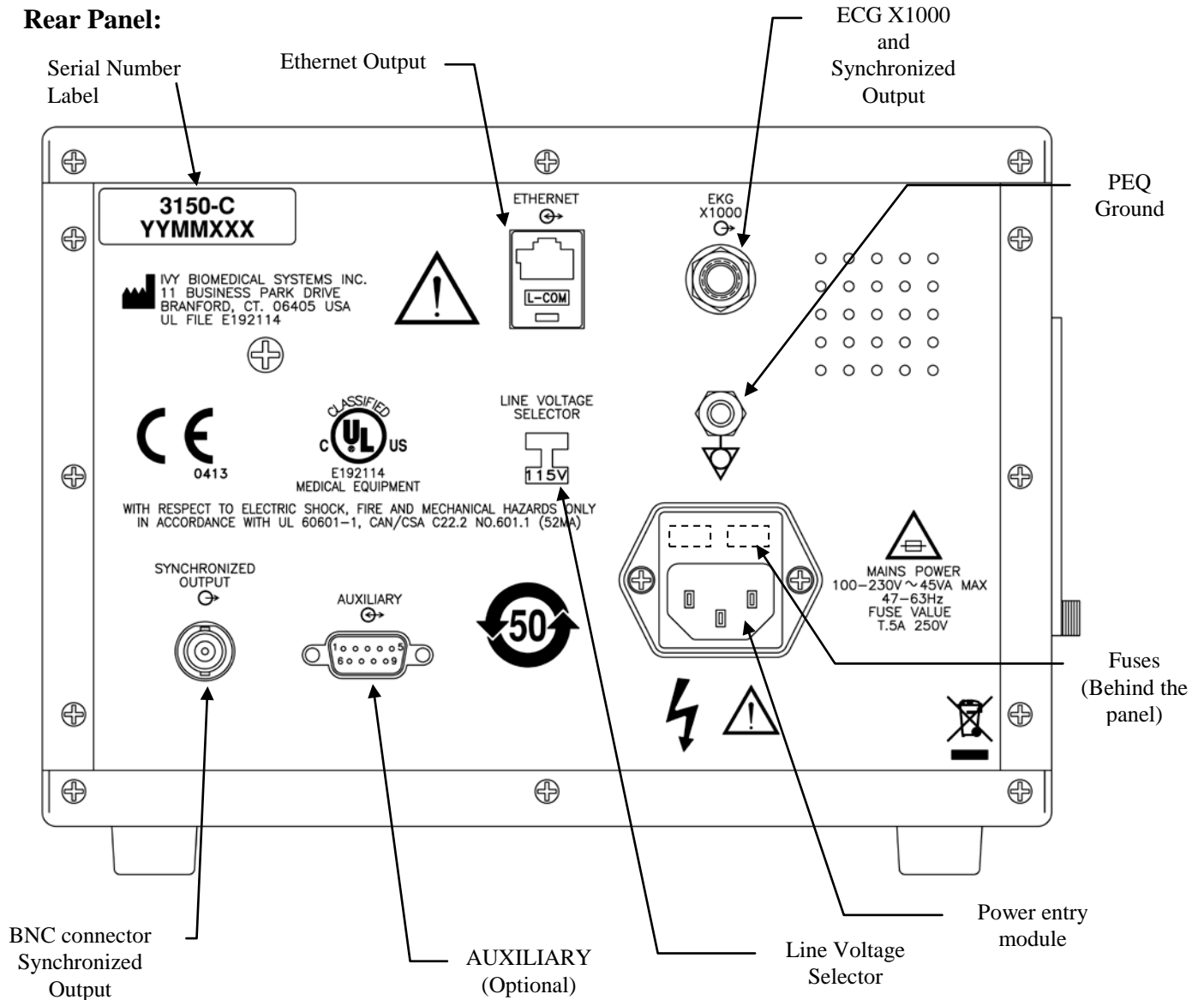

Fuse Ratings

The fuses are located behind the cover of the power entry module. To replace the fuses, unplug the ac power cord. Remove the power entry module cover and replace the fuse(s) only with same type and rating T.5A, 250V (Metric 5x20mm).

MONITOR SETUP

MONITOR SETUP

To setup the instrument for operation

WARNING: Before this monitor is plugged into any power source verify visually that the line selector switch on the rear panel displays the appropriate voltage range for your location. For further instructions, see “To Change Mains Voltage” below.

1. Plug the ac line cord into a power source providing the proper voltage.
2. Press the **ON** switch at the left side of the front panel to turn power on.
3. Connect the patient cable to the ECG connector on the front panel.

To change Mains Voltage

1. Verify that the power cord is disconnected.
2. Locate the line voltage selector switch on the monitor rear panel.
3. If necessary move the selector switch to the appropriate voltage for your location (for assistance, contact your Maintenance Department).















To set the Language

Use the following procedure to change the language of the menu and messages.

1. Turn monitor off by pressing the STBY key.
2. Press and hold the fourth and fifth soft key (from left to right) while applying power to the monitor by pushing the ON key.
3. Press the [LANGUAGE] key to set the desire language. The language choices are: English, Spanish, French, German, Italian, Portuguese, Swedish, Danish, Dutch, Norwegian and Finnish.
4. Turn monitor off by pressing the STBY key.

To set the Time, Date and Audio

Use the following procedure to set the date and time. The time is indicated in the upper left corner of the display.

1. Press the [SETUP] key in the main menu.
2. Press the [VOL/CLOCK] key to access the Vol/Clock menu.
3. The first setting is for QRS VOL. Use the  and  keys to increase or decrease the QRS VOL setting.
4. Press [NEXT] to move to the ALARM VOL setting. Use the  and  keys to increase or decrease the ALARM VOL setting.
5. Press [NEXT] to move to the MONTH setting. Use the  and  keys to increase or decrease the month setting.
6. Press [NEXT] to move to the DAY setting. Use the  and  keys to increase or decrease the day setting.
7. Press [NEXT] to move to the YEAR setting. Use the  and  keys to increase or decrease the year setting.
8. Press [NEXT] to move to the HOUR setting. Use the  and  keys to increase or decrease the hour setting.
9. Press [NEXT] to move to the MINUTE setting. Use the  and  keys to increase or decrease the minute setting.

When all date, clock and audio settings are correct, select [EXIT] to enter the settings into the monitor’s memory.

To set the Trace Speed

1. Press the [SETUP] key in the main menu.
2. Press the [ECG] key.
3. Press the [OPTIONS] key.
4. Press the [SPEED] key to select the trace speed. Selections are 25, and 50 mm/s.

NOTE: The [SPEED] key also changes the speed of the recorder.

Default Settings

To reset the monitor to the default settings, turn monitor off by pressing the STBY key; then press and hold the fourth and fifth soft key (from left to right) while applying power to the monitor by pushing the ON key.

Setting	Initial Default
Auto-Impedance Checking	OFF
Initial Language Setting	English
ECG Size	10mm
Lead	II
Trigger output/mark	ON
ECG Notch filter	ON
Impedance	Enabled
Impedance Threshold	50k Ω
Impedance Auto	OFF
Pacer Detect	Disabled
P-Lock	Enabled
Heart Rate Low Limit	30
Heart Rate High Limit	160
Trace Speed	25mm/sec
Recorder	Direct
QRS Volume	OFF
Alarm Volume	High
Alarms	Paused 30 sec., then ON

Some settings (see list below) are stored in non-volatile memory which means that the monitor powers up with the same options that were in effect when power was last turned off.

Setting	Options				
Speed	25mm/sec	50mm/sec			
Recorder	Direct	Timed	Delay	X-Ray	HR-Var
Alarm Vol.	High	Low			
P-Lock	Enabled	Disabled			

TRIGGER OUTPUT

SYNCHRONIZED OUTPUT (Trigger)

The Synch Pulse

The ECG Synchronized Output produces a trigger pulse starting at the peak of each R-wave, which is available on the **SYNCHRONIZED OUTPUT** BNC connector and on the **ECG X1000** output (ring on the ¼" stereo jack) connector on the rear panel of the monitor. Connect the Synchronized Output from the monitor to the device being synchronized.

The following shows the timing of the trigger pulse compared to the ECG waveform.

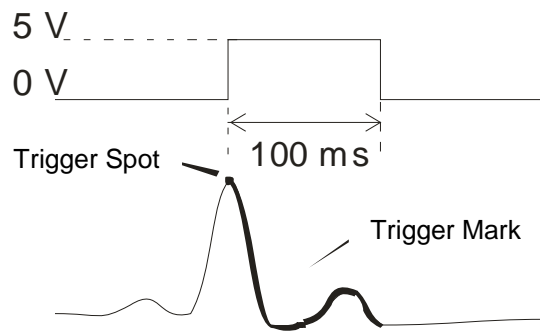

Trigger-Mark Display

The Synchronized trigger output is always active. A portion of the ECG waveform corresponding to the timing of the synch pulse is highlighted in red.

If the trigger function appears to be erratic verify the following:

- Select lead with the highest amplitude, typically Lead II.
- The proper placement of the ECG electrodes. The ECG electrodes may need to be repositioned.
- The ECG electrodes still have moist conductive gel.

Polarity Lock (P-LOCK)

With some patients' ECG's the shape of a tall T wave or deep S wave sometimes matches the criteria used to detect the R wave. When this situation occurs the monitor correctly detects the R wave and then falsely detects the T wave or S wave causing double triggering. The polarity control algorithm (P-Lock) reduces the number of false triggers when tall T waves or deep S waves occur. The P-Lock algorithm allows the Model 3150-C to detect and trigger only at the peak of the R wave, rejecting most of the tall T waves and deep S waves that might have caused false triggers. To turn P-Lock ON / OFF follow the next steps:

1. Press the [SETUP] key and press the [ECG] key to access the ECG menu.
2. Press the [OPTIONS] and select [P-LOCK] to enable or disable the P-Lock algorithm.
3. Press EXIT to return to the main menu.

ECG MONITORING

When ECG monitoring, the ECG waveform moves across the display from left to right. The heart rate, heart rate alarm limits, and lead selection are displayed in the upper left corner together with alarm messages. Also, a heart symbol flashes each time a heartbeat is detected.

Safety Considerations



Disposable products are intended for single-use only. Do not attempt to re-use these products.

ECG Patient connections are electrically isolated **Type CF**  for ECG connections use insulated probes. Don't let patient connections contact other conductive parts, including earth. See instructions for patient connections in this manual.

This monitor is supplied with protected lead wires. *Do not use* cables and leads with unprotected lead wires having exposed conductors at the cable end. Unprotected lead wires and cables may pose an unreasonable risk of adverse health consequences or death.

Leakage current is limited internally by this monitor to less than 10 μA . However, always consider cumulative leakage current that can be caused by other equipment used on the patient at the same time as this monitor.

To avoid the potential of electrosurgery burns at ECG monitoring sites, ensure proper connection of the electrosurgery return circuit as described by manufacturer's instructions. If improperly connected, some electrosurgery units might allow energy to return through the electrodes.

Line isolation monitor transients may resemble actual cardiac waveforms and thus inhibit heart rate alarms. To minimize this problem, ensure proper electrode placement and cable arrangement.

Rate meters might continue to count the pacemaker rate during occurrences of cardiac arrest or some arrhythmias. Do not rely on rate meter alarms. Keep pacemaker patients under close surveillance.

ECG MONITORING

Patient Connections

To ensure compliance with safety and performance specifications, use the patient cables supplied by Ivy Biomedical Systems (see Accessories). Other cables might not produce reliable results.

Use only high quality silver/silver-chloride short term monitoring ECG electrodes such as Ivy part number: 590342.

Use only high quality silver/silver-chloride ECG Electrodes or equivalent. For best ECG performance, use ECG Electrodes supplied by Ivy Biomedical Systems (see Accessories).

Use the following procedure for ECG monitoring:

1. Prepare each electrode site and apply the electrodes.
2. Connect the patient cable to the monitor's front panel ECG input.
3. Connect the leads to the patient cable.
4. Attach the leads to the electrodes.
5. Use the procedures described in the following sections for alarm limit settings, lead selection, amplitude adjustment, and enabling or disabling the filter. See the menu diagram below.

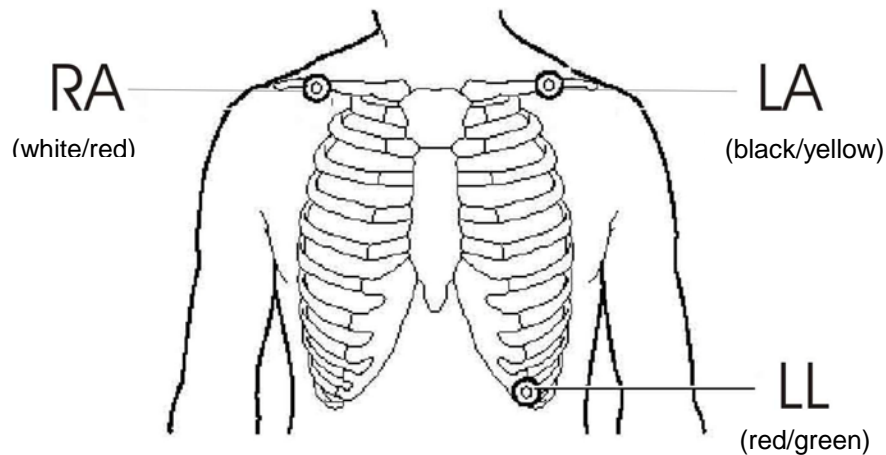

ECG Electrodes

ECG electrodes vary in both construction and quality between the different manufacturers, however typically there are two main groups, long term monitoring electrodes and short term monitoring electrodes. Ivy recommends the use of short term monitoring electrodes which stabilize faster due to their higher chloride content. For the best performance Ivy especially recommends the Ivy ECG Electrodes (Ivy P/N: 590342 / GE P/N: E8007RG).

Prior to applying the ECG electrodes to the patients skin, Ivy recommends preparing the electrode location by rubbing the skin with a dry gauze pad or alternatively, if it is necessary to remove cream or powder from the patients skin, warm soapy water .

Impedance Measurement

The Model 3150-C has unique hardware and software which allows the measurement and identification of the impedance value between the patient's skin and each individual ECG electrode. (RA, LA, and LL).

The purpose of the impedance measurement is to verify proper skin preparation and proper ECG electrode application and to assure a good ECG signal and therefore a reliable trigger pulse. Ivy recommends that the impedance value of each ECG connection be less than 50,000 Ω (50k Ω). The use of the wrong type of ECG electrodes, improper application or poor skin preparation can increase the electrode impedance value, causing an imbalance between the leads which can allow noise to be induced into the ECG signal which can cause inaccurate trigger pulses.

- In the standard default mode the impedance value of each ECG electrode can be measure by pressing the **Measure Impedance** soft key on the main menu screen (See below).
- The impedance value is displayed in the top right hand quadrant of the display.
- Impedance values of less than 50k Ω are displayed in green.
- Should any electrode impedance value be over 50k Ω , the appropriate lead(s) will flash the value in red indicating that the value is outside the recommended range.
- If the measurements are in red remove the ECG electrodes and clean the skin with a gauze pad before re-applying a fresh ECG electrode.
- For proper skin preparation follow the instructions indicated on the ECG electrode packaging.
- Re-measure skin impedance after 1-2 minutes of repositioning electrodes on the patient skin.

The Model 3150-C can also be set up to take two measurements after the LEAD OFF alarm disappears. The measurements will occur at 30 and 60 seconds intervals after the LEAD OFF alarm is inactive. For information on how to activate this feature contact your local GE Healthcare Field Engineer or contact Ivy biomedical Systems Inc at (203) 481-4183.

ECG MONITORING

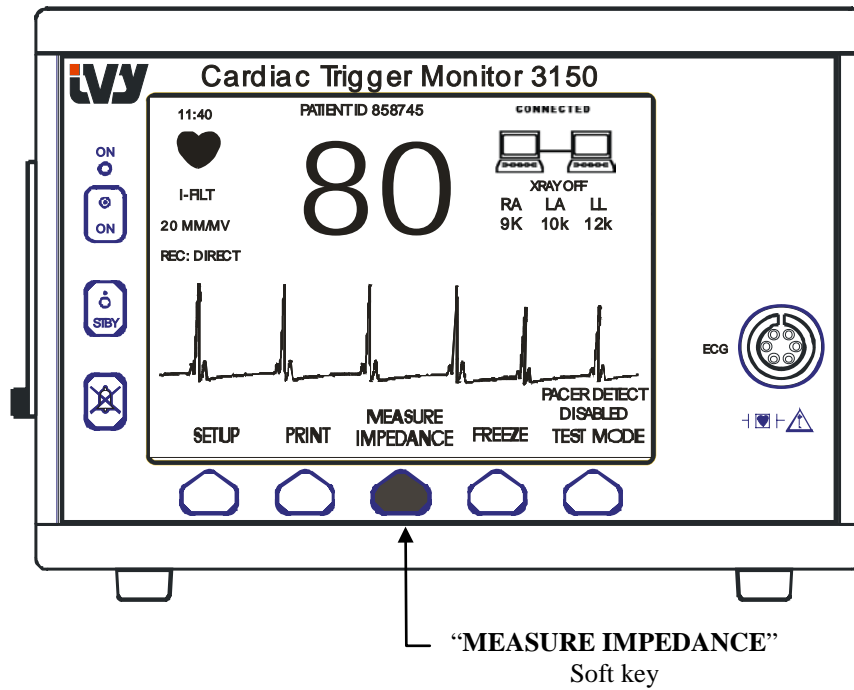

ECG Waveform Amplitude (Size)

Use the following procedure to adjust the amplitude (size) of the displayed ECG waveform.

1. Press the [SETUP] key from the main menu. The following menu appears.

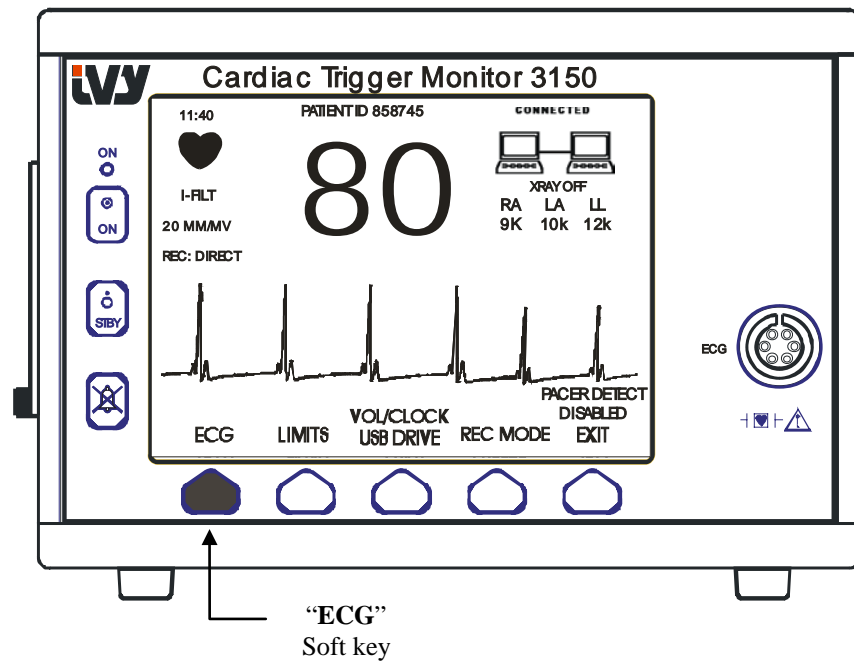

2. Press the first programmable key [ECG] once to select ECG.

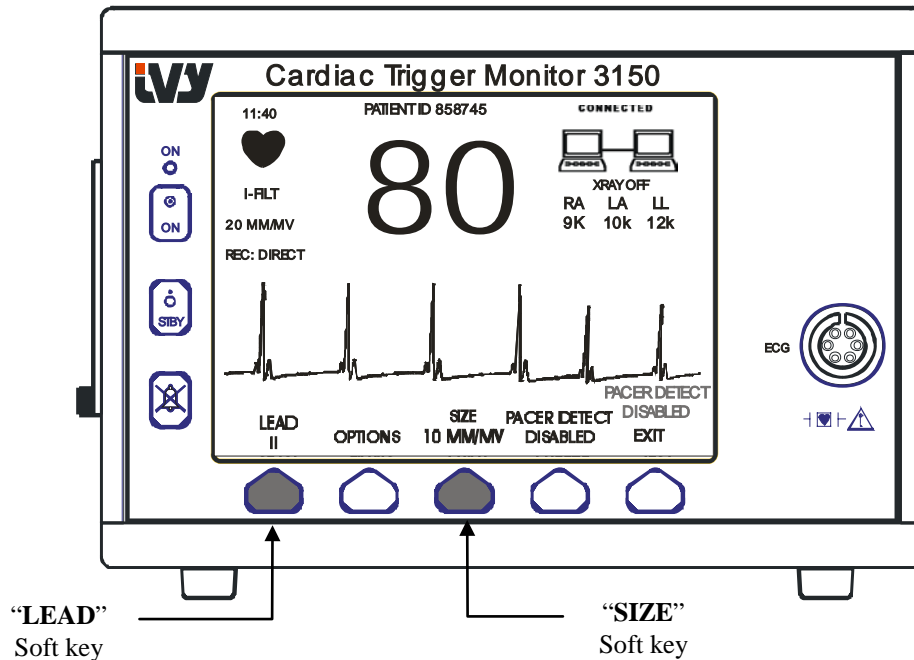

3. Use the third programmable key to adjust the ECG waveform amplitude.
4. Press [EXIT] to return to the main menu.

Lead Selection

1. Press the [SETUP] key from the main menu.
2. Press the first programmable key [ECG] once to select ECG.
3. Select [LEAD] to change the lead selection. The current lead selection is shown above the alarm limits in the upper left portion of the display. Available lead selections are Lead I, Lead II, or Lead III.
4. Press [EXIT] to return to the main menu.

ECG MONITORING

Low Signal Message

If the amplitude of the ECG signal is between $300\mu\text{V}$ and $500\mu\text{V}$ (3-5mm of amplitude at size 10mm/mv) for a period of eight seconds a LOW SIGNAL message will be displayed in yellow below the ECG waveform.

If the trigger function appears to be erratic while the message is displayed verify the following:

- Select lead with the highest amplitude, typically Lead II.
- The proper placement of the ECG electrodes. The ECG electrodes may need to be repositioned.
- The ECG electrodes still have moist conductive gel.

ECG Notch Filter

Use the following procedure to activate the Notch filter:

1. Press the [SETUP] key from the main menu.
2. Press the [ECG] key and select the [OPTIONS] key.
3. Select [NOTCH FILTER] to turn the filter on or off. When the filter is on, the "FILT" indicator is shown in the upper left portion of the display. The filter sets the frequency response of the displayed waveform as follows:

Filtered: 1.5 to 35 Hz
Unfiltered: 0.2 to 100 Hz

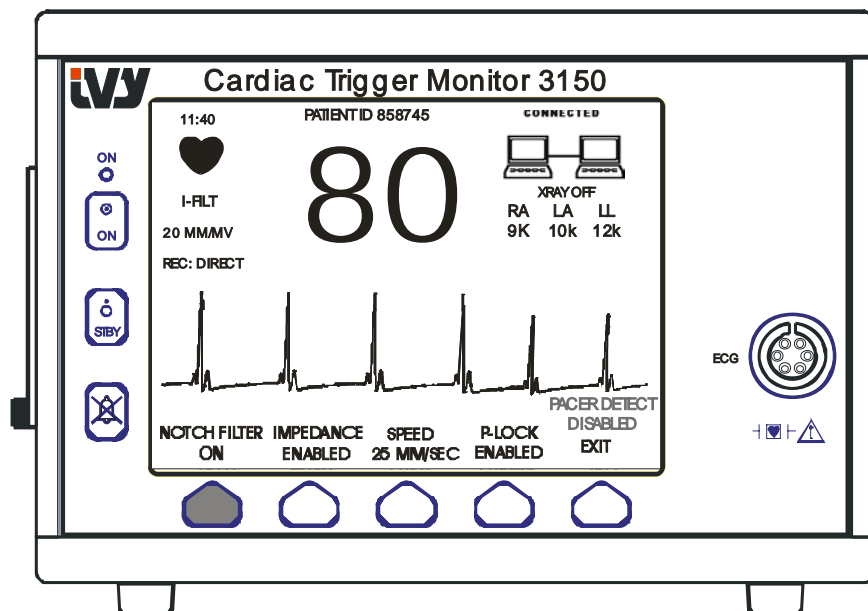

4. Press [EXIT] to return to the main menu.

Alarm Limits

1. Press the [SETUP] key from the main menu. The following menu appears.
2. Press the programmable key [LIMITS] to enter the Alarm Limits menu.
3. Use the programmable keys to set the high and low heart rate limits.

↑	Increases high HR limit
↓	Decreases high HR limit
↑	Increases low HR limit
↓	Decreases low HR limit

Each time you press a key, the corresponding limit changes by 5 bpm. The current HR limits are always shown in the upper left portion of the display.

4. Press [EXIT] to return to the main menu.

Alarm Type	Default Limit
Heart Rate Low	30
Heart Rate High	160

Pacemaker

Follow the next procedure to activate or deactivate the pacemaker detection function:

1. Press the [SETUP] key from the main menu.
2. Press the [ECG] key and then select the [PACER DETECT] key to toggle between pacer detection enabled or disabled.

When a pacemaker has been detected, a **P** will start flashing in the heart symbol.

The message “PACER DETECT DISABLED” will appear if the pacer detection circuit is not active.

WARNING: Rate meters might continue to count the pacemaker rate during occurrences of cardiac arrest or some arrhythmias. Do not rely on heart rate alarms. *Keep pacemaker patients under close surveillance.*

SYSTEM INTERLOCK OPERATION

SYSTEM INTERLOCK OPERATION

System Interlock Messages

When the Model 3150-C is interfaced via the rear auxiliary connector to a CT Scanner, the monitor can store ECG data and transfer this data to a USB Memory Stick .

The system interlock feature is designed to indicate to the system operator:

1. That the monitor and the CT Scanner “is connected” or the CT Scanner is “not connected”
2. That the CT-Scanner X-Ray is “ON” or the CT Scanner X-Ray is “OFF”.

1. Large symbols in the upper right hand corner of the display provide the operator with a visual indication of the status of the connection between the monitor and the CT Scanner

NO CONNECT



This symbol indicates that the Model 3150-C and the CT Scanner ARE NOT interfaced correctly.

CONNECTED



This symbol indicates that the Model 3150-C and the CT Scanner ARE interfaced correctly.

2. Additional information is provide to the operator concerning the status of the CT Scanner X-Ray. In a window just below the **CONNECTED** symbol a text message is displayed. When the CT Scanner X-Ray is off **XRAY OFF** is displayed. When the CT Scanner X-Ray is on **XRAY ON** is displayed.

PATIENT IDENTIFICATION NUMBER

Patient Identification and other controls using ETHERNET MODE

When the Model 3150-C is connected to the CT console and the Ethernet mode is selected, the alphanumeric Patient ID is entered on the CT console, and transmitted to the Model 3150-C monitor. The first 12 characters of the Patient ID are shown at the top of the display above the heart rate. The same Patient ID is also stored for transmission back to the CT console if a subsequent Data Recall operation is performed.

In addition to the Patient ID, the user may enter other information via the CT console which is transmitted to the Model 3150-C monitor. For example, the SCAN DELAY and SCAN WIDTH may be set. These are shown on the right side of the display, and used to annotate (in color) the scan period on the ECG trace.

For additional information on how to enter the Patient ID as well as the other remote controls, refer to the CT Scanner Operation Manual.

ECG DATA STORAGE AND TRANSFER

ECG DATA STORAGE AND TRANSFER

ECG and Impedance Data Transfer using the USB Port

The Model 3150-C has a USB port that allows the user to connect a USB memory stick and retrieve up to 100 ECG events and measured impedance data stored in the monitor.

ECG data is stored in the monitor when the X-RAY signal from the CT scanner becomes active, and the ECG data storage stops 10 seconds after the X-RAY signal becomes inactive. ECG data is stored at two resolutions: low resolution (240Hz sample rate) and high resolution (800 Hz sample rate).

The ECG data can be downloaded to a memory stick device (512MB minimum) by following these steps:

1. Plug a USB memory drive (minimum 512K) in to the USB port on the side of the monitor.
2. From the main menu, press the SETUP key and then select VOL/CLOCK/USB DRIVE key.
3. Select USB Drive key and press the COPY TO USB DRIVE key.
4. When all the data has been downloaded on to the memory stick, press CLEAR MEMORY to delete the ECG data from the monitor memory or press EXIT to return to the main menu.

USBPort



The Model 3150-C USB port is be used only for the transfer of internal data to an external media using a standard USB type memory drive (memory stick) with a minimum capacity of 512 MB. The connection of any other type of USB device to this port could result in damage to the monitor.

Note: The USB memory device used with this port **MUST NOT BE POWERED FROM AN EXTERNAL SOURCE**

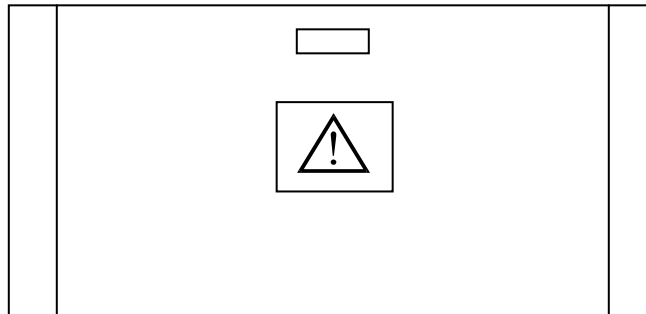

RECORDER OPERATION

Changing Paper

Replace the roll of thermal paper as follows. (Recorder paper is Ivy P/N: 590035)

1. Press the paper eject button to open the door at the front of the recorder.

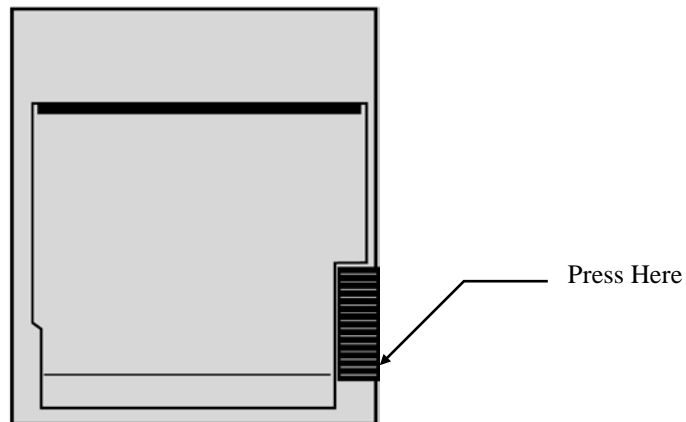

If the door does not open completely, pull it toward you until it is completely open.

2. Reach in and remove the spent paper core by pulling it gently toward you.
3. Place a new paper roll between the two round tabs of the paper holder.
4. Pull some paper from the roll. Make sure the sensitive (shiny) side of the paper faces the print head. The shiny side of the paper normally faces inside the roll.
5. Align the paper with the pinch roller on the door.

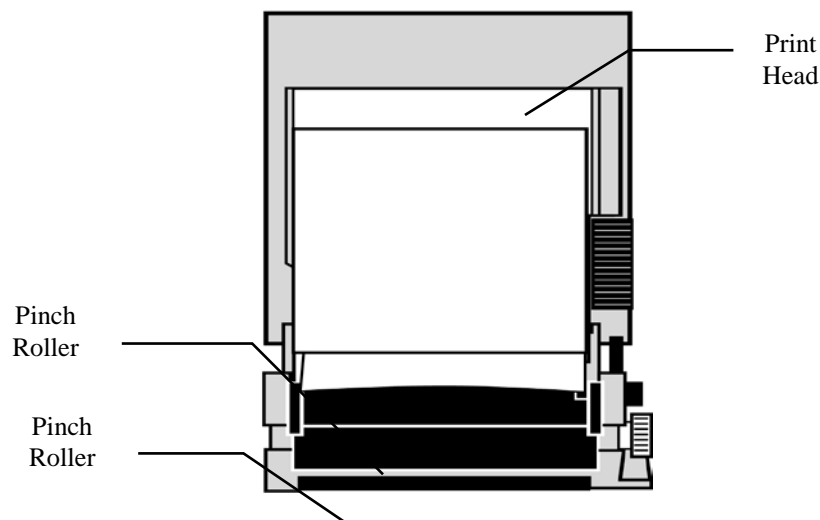

6. Hold the paper against the pinch roller and close the door.

RECORDER OPERATION

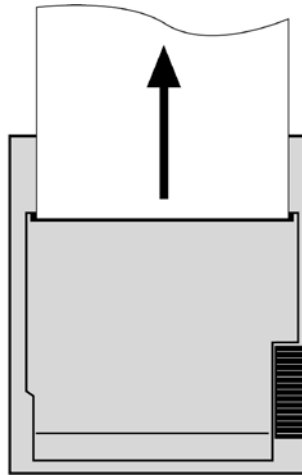

Recorder Modes

Use the following procedure to select the printing mode to be used. Selections are DIRECT, TIMED, DELAY, HR-VAR, and X-RAY.

The print mode is indicated in the left center of the display.

1. Press the [SETUP] key from the main menu. .
2. Press the programmable key [REC MODE] to select the printing mode.

Direct To print in direct, press the [PRINT] key. Press [PRINT] again to stop printing.

The plot is preceded by a header which contains all parameter readings and the time/date.

The speed of the plot and vertical resolution are the same as the display. The plot is labeled with the speed of the plot in mm/s, the recorder mode, and the parameters.

Timed TIMED mode starts by pressing [PRINT] and prints for 30 seconds.

Delay Delay mode plots 30 or 40 seconds of ECG waveform after the occurrence of an alarm condition or if print button is pushed depending on the speed selected:

15 seconds before and 15 seconds after at 50mm/s

20 seconds before and 20 seconds after at 25mm/s

HR-VAR This mode enables an additional delay mode, where the printout is triggered by a beat to beat heart rate change of a given percentage (10-50% in increments of 5) as specified in the menu. Lead wires must be on the patient for at least 30 seconds to enable this mode. The Recorder plots a waveform similar to the one of the delay mode after the occurrence of the heart rate change.

X-RAY This mode prints a trace showing 10 seconds before and 10 seconds after the XRAY signal is activated. The XRAY signal and the ECG trace are printed together.

Recorder Speed

Use the following procedure to change the recorder speed.

1. Press the [SPEED] key in the main menu to select the trace speed. Selections are 25, and 50 mm/s.

NOTE: The [SPEED] key also changes the speed of the ECG trace.

Example Printout

Direct Mode

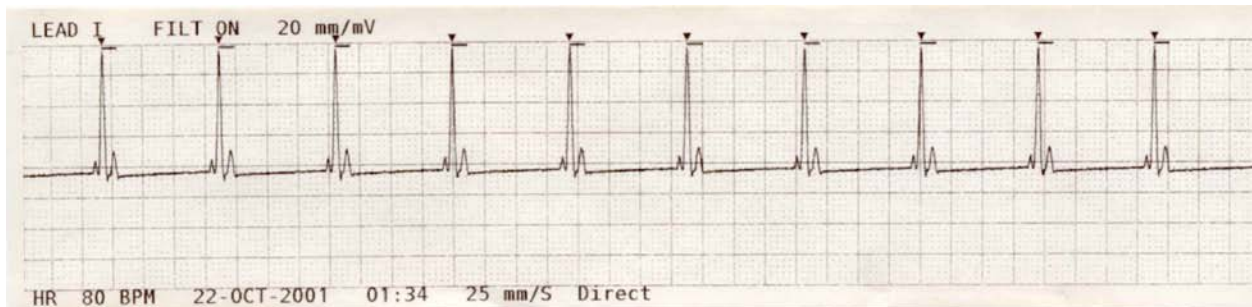

X-Ray Mode

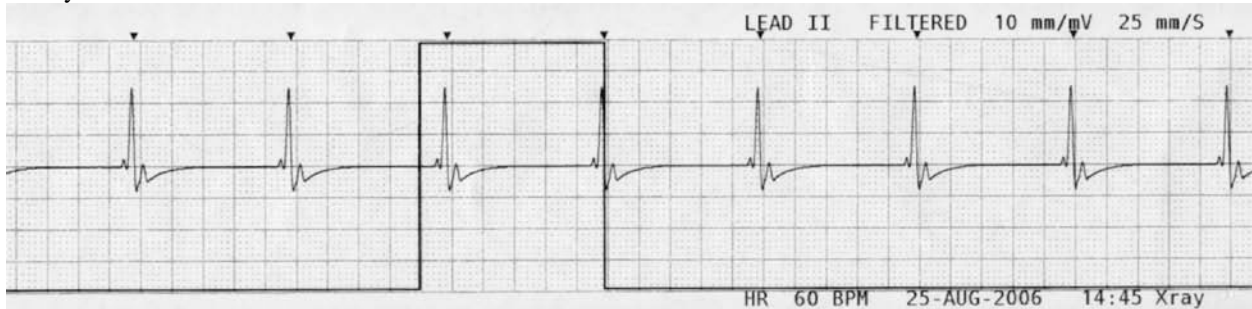

ALARM MESSAGES

The following alarm messages are displayed in red letters:

PAUSE: All audible and visual alarms are turned off for 120 seconds.

To activate alarm **PAUSE** press  key once.

To cancel alarm **PAUSE** wait for 120 second **PAUSE** cycle to expire or press  key again.

WARNING: The monitor always powers on with the ALARMS paused for 30 seconds and then they are set to ON.

ALARMS OFF: All audible and visual alarms have been turned off:

To turn all audible and visual **ALARMS ON** press  key once.

To turn all audible and visual **ALARMS OFF** press and hold  key for three seconds.

The following alarm messages are displayed in flashing reverse video. White letters on a red back ground flashing at a rate of once every second with an audio frequency of 4 KHz.

Press  key to reset all alarms except **LEAD OFF**.

HR HIGH: The high heart rate alarm limit has been exceeded for four seconds.

HR LOW: The low heart rate alarm limit has been exceeded for four seconds.

ASYSTOLE: The interval between heartbeats has exceeded six seconds.

LEAD OFF: A lead has become disconnected or the electrode offset potential has exceeded ≥ 0.5 V

This alarm cannot be reset with the  key .

Low Signal Message

If the amplitude of the ECG signal is between $300\mu\text{V}$ and $500\mu\text{V}$ (3mm to 5mm at size 10mm/mv) for a period of eight seconds a “LOW SIGNAL” message will be displayed in yellow below the ECG waveform (see ECG monitoring section).

Pacer Detect Message

The message “PACER DETECT DISABLED” will appear if the pacer detection circuit is disabled through the ECG menu.

Check Electrode Message

The “CHECK ELECTRODE” message will flash in yellow should any electrode impedance value be over $50\text{k}\Omega$. The appropriate lead(s) will flash the value in red indicating that the value is outside the recommended range.

MONITOR TESTING

MONITOR TESTING

Press the [TEST] key to test the internal functions of the monitor. You should do this each time you begin monitoring a patient.

The [TEST] function generates a 1 mV pulse at 70 BPM, causing a waveform and a 70 BPM indication on the display and a signal at the rear panel connector. If these indications are not present, contact qualified service personnel.

To test the visual and audio alarms turn on the monitor. Make sure the ALARMS OFF message is not present in the

center portion of the display. If the alarms are off press the  key. Unplug the patient cable. Check that the LEAD OFF message is displayed on the ECG channel and the audio alarm is on. While pressing the TEST key check for the following to happen: 1) LEAD OFF message disappear, and 2) Monitor starts counting QRS. Stop

pressing the TEST key and press  for three seconds, the message PAUSE and the timer should be displayed on the display, all audio and visual alarms should be off

Under normal operation, no internal adjustment or recalibration is required. Safety tests and internal adjustments should be done by qualified personnel only. Safety checks should be performed at regular intervals or in accordance with local or governmental regulations. In the event that internal adjustment or recalibration is necessary, refer to the Operation and Service Manual for this equipment.

Note:

If no display is visible on the monitor, the monitor is inoperable. Contact qualified personal. When ECG input is >0.5 V, a inoperable condition is indicated by flashing LEAD OFF indicator on the display.

ECG Simulator

The Model 3150-C has an integrated ECG simulator that is used to verify the integrity of the patient cable, lead wires and electronic circuits involved in the processing of the ECG signal.

The simulator terminals are located in the right side panel of the monitor and have three color coded labels for easy identification. The terminals are used to attach the lead wires. The simulator generates an ECG waveform and heart rate within 40-150bpm range (user selectable). When the simulator is on, a message "SIMULATOR ON" is displayed in the center of the screen below the ECG trace.

ECG Simulator operation

To turn the simulator on and set the heart rate, follow the procedure below:

1. Press the [TEST MODE] key located in the main menu to access the simulator mode menu.
2. Press the key [SIM RATE] to turn the simulator on and toggle through the heart rate options.
3. Press the keys [↑ FINE TUNE ↓] to change the heart rate in increments of one.
4. Press [EXIT] to exit the test mode menu.

NOTE: When the simulator is on, a message "SIMULATOR ON" is displayed in the center of the screen below the ECG trace.
--

TROUBLESHOOTING

Problem	Verify that:
<ul style="list-style-type: none">• Unit does not turn on.	<ul style="list-style-type: none">✓ Power cord is plugged into the monitor and the AC outlet.✓ Line Voltage selector is in the appropriate position.✓ Fuses are not blown.✓ The ON switch is pressed.
<ul style="list-style-type: none">• Trigger pulse is not functional	<ul style="list-style-type: none">✓ The Auxiliary port connector is plugged into the monitor.✓ ECG size is optimal (select Lead II)
<ul style="list-style-type: none">• Erratic ECG waveform. Heart Rate is not counting.	<ul style="list-style-type: none">✓ ECG waveform has enough amplitude (Select Lead II).✓ Electrodes placement (see ECG section for proper placement diagram).✓ ECG electrodes have enough conductive gel.
<ul style="list-style-type: none">• System Interlock symbol does not show connection	<ul style="list-style-type: none">✓ Auxiliary port is connected

MAINTENANCE AND CLEANING

MAINTENANCE AND CLEANING

The Monitor

When necessary, clean the exterior surfaces of the monitor with a cloth or swab dampened with a warm water and mild detergent solution. Do not allow liquids to enter the interior of the instrument.

CAUTION:

- Do not autoclave, pressure sterilize, or gas sterilize the monitor.
- Do not soak or immerse in any liquid.
- Use cleaning solution sparingly. Excessive solution can flow into the monitor and cause damage to internal components.
- Do not touch, press or rub the display and covers with abrasive cleaning compounds, instruments, brushes, rough surface materials, or bring them into contact with anything that could scratch the display or the covers.
- Do not use petroleum based or acetones solutions, or other harsh solvents, to clean the monitor.

Patient Cables

Do not autoclave the patient cables.

Wipe the cables using a mild detergent solution. Never submerge the cables in any liquid or allow liquids to enter the electrical connections.

Preventive Maintenance

ECG

Check before connecting the monitor to a new patient that:

- Cables and Leads are clean and intact.
- The LEAD OFF message is displayed when the patient cable is connected, but the patient leads are not connected. Connecting the patient leads together should make the message disappear.
- The BNC Interconnect cable is clean and intact.

NOTE: There are no user serviceable items contained in the Model 3150-C.
--

ACCESSORIES

ECG

Ivy P/N	GE P/N	Description
590317	E8007RE	Low noise, three lead ECG patient cable
590318	E8007RH	Set of three radiotranslucent lead wires – 24in.
590341	E8007RF	Set of three radiotranslucent lead wires – 30in.
590342	E8007RG	Case of 600 Radiotranslucent ECG electrodes (20 bags of 590342)
590035	E8500BC	Recorder paper, pack of 10 rolls
590368	E8007RJ	Recorder paper, case of 100 rolls
590386	E8007RR	USB memory stick
590297	E8007RK	Roll stand

To order accessories please contact customer service:

- Tele: (800) 247-4614
- Tele: (203) 481-4183
- Fax: (203) 481-8734
- E-mail: sales@ivybiomedical.com

Disposal

Disposal of devices or consumables must be done in accordance with local, state, and federal laws and regulations.

WEEE Directive 2002/96/EC.- Do not dispose of WEEE products in general waste. At the end of life of product contact IVY Biomedical Systems, Inc. customer service for return instructions.

See Addendum 1 for a table of hazardous substances and their concentrations.

SPECIFICATIONS**ECG**

Lead Selection:	LI, LII, LIII menu selectable.
Patient Cable:	6-Pin AAMI Standard connector
Isolation:	Isolated from ground related circuits by >4 kV rms, 5.5 kV peak
CMRR:	≥90 dB with patient cable and 51 kΩ/47 nF imbalance
Input Impedance:	≥20 MΩ at 10 Hz with patient cable
Frequency Response LCD Display and Recorder:	Filtered: 1.5 to 35 Hz Unfiltered: 0.2 to 100 Hz
Frequency Response X1000 output:	Filtered: 0.2 to 40 Hz Unfiltered: 0.2 to 100 Hz
Input Bias Current:	Each lead <100 nA dc maximum
Electrode Offset Potential:	±0.5 V DC
Lead Off sensing current:	56nA
Noise:	<20 μV peak-to-peak, referred to the input with all leads connected through 51 kΩ/47 nF to ground
Defibrillator Protection:	Protected against 360 J discharge and electrosurgery potentials Recovery time <6s
Leakage Current:	<10 μA at normal condition
Electrosurgical Interference Protection:	Standard. Recovery time: <6 seconds.
Notch Filter:	50/60 Hz (automatic).

Cardiotach

Range:	15 to 260 BPM
Accuracy:	±1%
Resolution:	1 BPM
Sensitivity:	300 μV peak
Heart Rate Averaging:	Exponential averaging calculated once a second with a maximum response time of 8 seconds.
Response Time:	≤ 8 seconds
Tall T Wave Rejection:	Rejects T waves ≤R wave

SPECIFICATIONS

Pacer Pulse Rejection

Width:	0.1 to 2 ms at ± 2 to ± 700 mV
Overshoot:	Between 4 to 100ms and not greater than 2mV.
Fast ECG signals:	2mV/100 μ s.
Detector disabling:	None.

NOTE: Pacemaker pulses are not present in any rear panel outputs.

Alarms

High Rate:	15 to 250 bpm in 5 bpm increments
Low Rate:	10 to 245 bpm in 5 bpm increments
Asystole:	R to R interval >6 seconds
Lead Off:	Detached lead or offset potential >0.5 V

Simulator Option

ECG waveform amplitude:	1mV
Simulator rate:	Variable rate in steps of 40, 60, 90, 120 and 150 BPM Also, manually adjustable in increments of 1 BPM.

Test Mode

ECG:	1 mV/100 ms @ 70 bpm
------	----------------------

Display

Type:	Active Matrix TFT Color LCD (640x480)
Trace:	Single ECG trace with "freeze" function.
Screen Size:	13.25cm x 9.94cm, 16.5cm (6.5in) diagonal
Sweep Speed:	25, 50 mm/s
Aspect ratio:	0.4 (standard). User selectable.

USB Port and Data Transfer

Type:	Industry standard USB Flash Drive (memory stick) minimum capacity of 512 MB
ECG storage:	100 most recent events (100 high resolution and 100 low resolution)
Impedance Values Storage:	100 most recent events

Ethernet Module

Network Interface:	RJ45 (10BASE-T)
Ethernet compatibility:	Version 2.0/IEEE 802.3
Protocol:	TCP/IP
Packet Rate:	250ms
ECG Data Rate:	240 samples/s
Default IP address:	10.44.22.21
Data Rates:	300bps to 115.2Kbps
Standard Temperature:	32 to 158°F (0 to 70°C)
Size:	1.574 x 1.929 in (40mm x 49mm)

Mechanical

Size:	Height: 6.70in. (17.2cm) Width: 9.25in. (33.5cm) Depth: 9.21in. (23.4cm)
Weight:	6.5lbs (2.9kg)

Recorder

Writing Method:	Direct Thermal
Number of Traces:	1
Modes:	Direct - Manual Recording Timed - Print button initiates a 30 second recording Delay - Records 20 seconds before and 20 seconds after an alarm XRAY - Records 10 seconds before and 10 seconds after an event HR-VAR - Records 20 seconds before and 20 seconds after an event
Paper Speeds:	25 and 50 mm/s
Resolution:	Vertical - 200 dots/in. Horizontal - 600 dots/in. at ≤ 25 mm/s 400 dots/in. at > 25 mm/s
Frequency Response:	> 100 Hz at 50 mm/s
Data Rate:	400 samples/s/trace

Synchronized Output (Trigger)

Test input signal at ECG leads:	$\frac{1}{2}$ sine wave, 60ms width, 1mV amplitude, 1 pulse per second
Output trigger delay:	< 6 ms w/ notch filter off. < 9 ms w/ notch filter on
R to R Trigger Accuracy:	$\pm 50\mu$ s typical @ 1 mV input
Pulse width:	100ms
Pulse amplitude:	0 to +5V
Output Impedance:	$< 100 \Omega$
Sensitivity and Threshold Adjustment:	Fully Automatic

Real Time Clock

Resolution:	1 minute
Display:	24 hours
Power Requirement:	The real time clock keeps time if the monitor has power or not. The clock is powered by a dedicated battery whose life is a minimum 4 years at a temperature of 25°C

Environmental

Operating Temperature Range:	5°C to 40°C
Storage Temperature Range:	-20°C to 49°C
Relative Humidity:	0-90% non-condensing
Atmospheric Pressure:	500-1060 mbar
Protection against ingress of fluids:	IPX0 – Ordinary (without protection against ingress of water)

Power Requirements

Voltage Input:	100 to 230V~
Line Frequency:	47 to 63 Hz
Fuses Type and Rating:	T.5A, 250V (Metric 5x20mm)
Maximum ac Power Consumption:	45 VA

Regulatory

Unit meets or exceeds the specifications for the AAMI Cardiac Monitor Standard EC-13, UL60601-1, CAN/CSA C22.2 No 601.1-M90, CDN MDR (CMDCAS), IEC 60601-2-25, IEC 60601-2-27, MDD.93/42/EEC, CE 0143, ISO 13485:1996, and FDA/CGMP.



ADDENDUM 1

Table of hazardous substances' name and concentration

Component name	Hazardous substances' name						
	Assembly Number	(Pb)	(Hg)	(Cd)	(Cr ⁶⁺)	(PBB)	(PBDE)
Main assembly	2700-00-01	X	O	O	O	O	O
Front assembly	2699-01-01	X	X	O	O	O	O
Rear Panel assembly	2697-00-01	X	O	O	O	O	O
Model Option	2738-12-15	X	O	O	O	O	O
Recorder Option	2739-01-15	X	O	O	O	O	O
ECG Simulator Option	2772-00-15	X	O	O	O	O	O
Accessory Option	2740-31-15	X	X	X	X	X	X

O: indicates hazardous substance concentration less than or equal to MCV
X: indicates hazardous substance concentration higher than MCV

The data above represents best information available at the time of publication.
Some consumable or OEM items may have their own label with an EFUP value less than the system and may not be identified in the table.



This symbol indicates the product contains hazardous materials in excess of the limits established by the Chinese standard SJ/T11363-2006. The number indicates the number of years the product can be used in normal conditions before the hazardous materials may cause serious harm to the environment or health of humans. This product must not be disposed of as unsorted municipal waste, and must be collected separately.

ADDENDUM 2

Model 3150 Installation Instructions

1. Remove the new monitor from the shipping carton.
2. Line up the new monitor and its adapter plate with the mounting plate on the roll stand. Pull down the safety pin and slide the monitor on the adapter plate. Release the safety pin and make sure safety pin is engaged in the adapter plate (The adapter plate has a hole to allow the safety pin to secure the monitor).



3. Before the monitor is plugged into any power source verify visually that the Line Voltage Selector switch displays the appropriate voltage range for your location.



Line Voltage
Selector Switch